

# Preliminary

## PO-TS3020ZCN-004

### 1. SPECIFICATIONS

#### (1) Absolute Maximum Ratings

(Ta=25°C)

Parameter	Symbol	MAX.	Unit
Continuous Forward Current	If	20	mA
Pulse Forward Current*	Ifp	100	mA
Reverse Voltage	Vr	5	V
Power Consumption	Pc	75	mW
Operating Temperature Range	Topr	-40 ~ +85	°C
Storage Temperature Range	Tstg	-40 ~ +100	°C
Electrostatic Discharge	ESD	150	V
Soldering Temperature	Tsld	Reflow Soldering:240°C/10sec Hand Soldering:350°C/3sec	

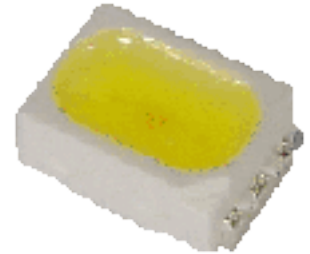

\*Duty 1/10 @ 1KHZ

#### (2) Electrical / Optical Characteristics

(Ta=25°C)

Parameter	Symbol	Min.	Typ.	Max.	Unit	Test Condition
Forward Voltage*	Vf	2.8	/	3.8	V	If=20mA
Luminous intensity*	Iv	480	590	/	mcd	If=20mA
Dominant Wavelength	$\lambda_d$	/	525	/	nm	If=20mA
Spectrum Radiation Bandwidth	$\Delta\lambda$	35	40	45	nm	If=20mA
Reverse Current	Ir	/	/	10	$\mu$ A	VR=5V
Viewing Angle	2 $\theta$ 1/2	/	120	/	Deg	*

\*Forward voltage measurement allowance is  $\pm 0.1V$ .

\*Luminous intensity is measured with a light sensor and filter combination that approximates the CIE eye-response curve.

\*Luminous Intensity Measurement Allowance is  $\pm 10\%$ .

\*Dominant Wavelength measurement allowance is  $\pm 1nm$ .

\*2 $\theta$ 1/2 is the off-axis angle at which the luminous intensity is half the axial luminous intensity.

\*Please see attachments for BIN classifications.

#### (3) Typical Electrical / Optical Characteristics Curves

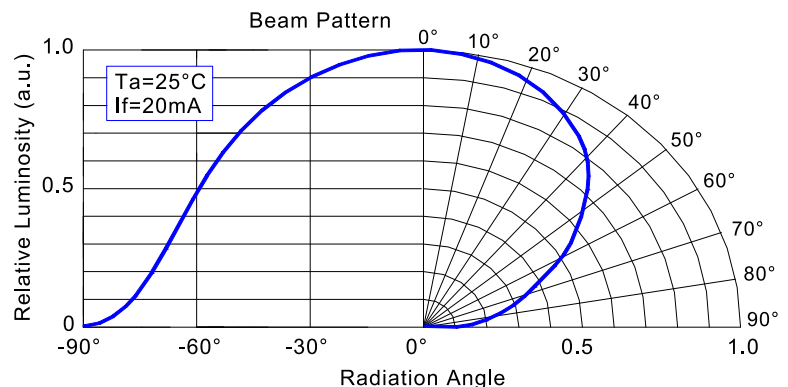
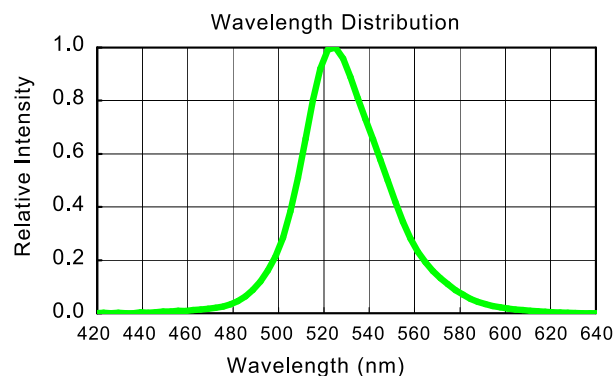

## 2. Package

### (1) Outline Dimension

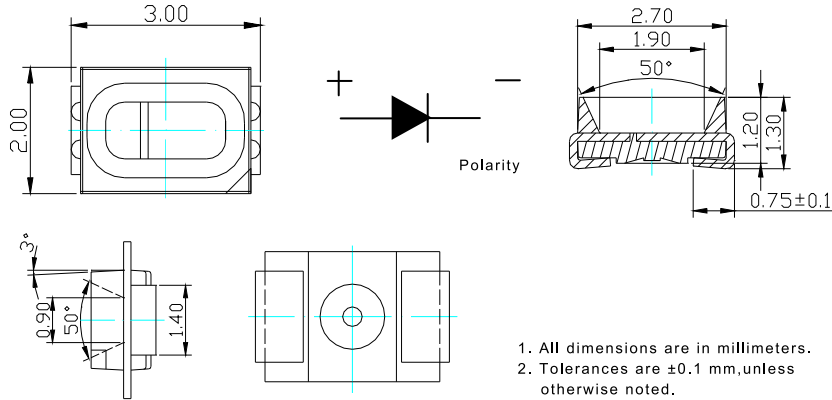

### (2) Taping Dimension (unit= mm)

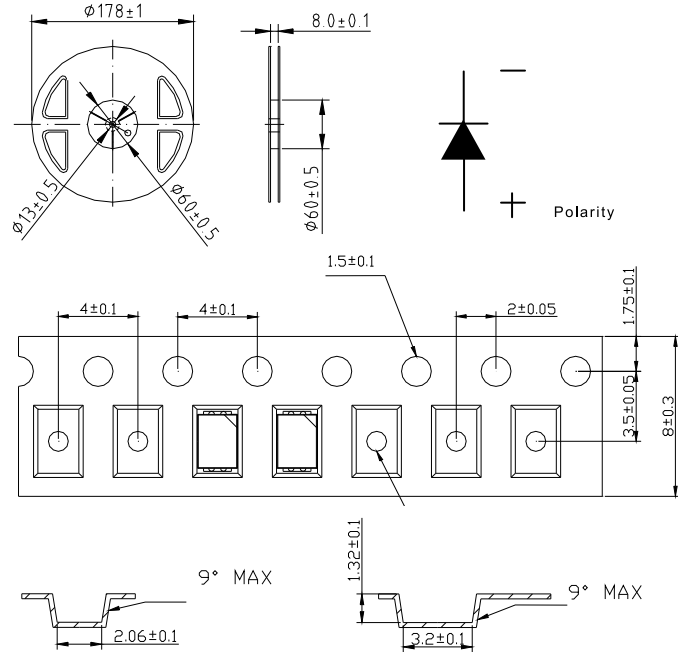

## 3. Handling Precaution

### (1) Recommended soldering conditions

#### 1.1 Reflow solder temperature profile

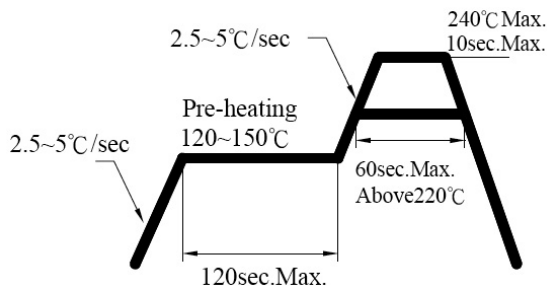

### 1.2 Recommended Soldering pad design (unit= mm)

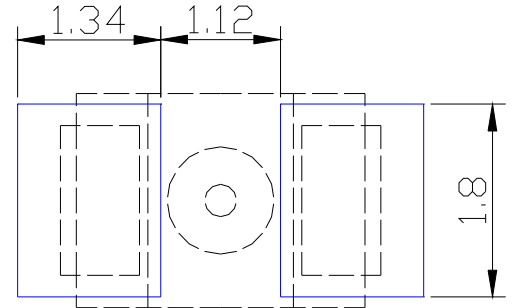

### 1.3 Soldering conditions

- Reflow soldering should not be done more than twice.
- When soldering, do not stress on LEDs during heating.
- After soldering, do not warp the circuit board.

### (2) Repairing

- Repair should not be done after the LEDs have been soldered. When repair is unavoidable, double-head soldering iron should be used. It should be confirmed beforehand whether the characteristics of the LEDs will be damaged by repair or not.

### (3) Cleaning

- It is recommended to use isopropyl alcohol as a solvent to clean the LEDs. When using other solvents, it should be confirmed beforehand whether the solvents will dissolve the package and the resin or not.

### (4) Advice on Device Usage

- It is recommended that user should complete the use of the whole package within 8 hours upon unsealing. In the event of incomplete usage, it is advised that user preheat the remaining devices at 60°C for 8 hours prior to use.